

RESİM DEĞİŞİKLİĞİNİ BİLDİRİNİZ.

TÜM ÖLÇÜLER mm CİNSİNDENDİR.

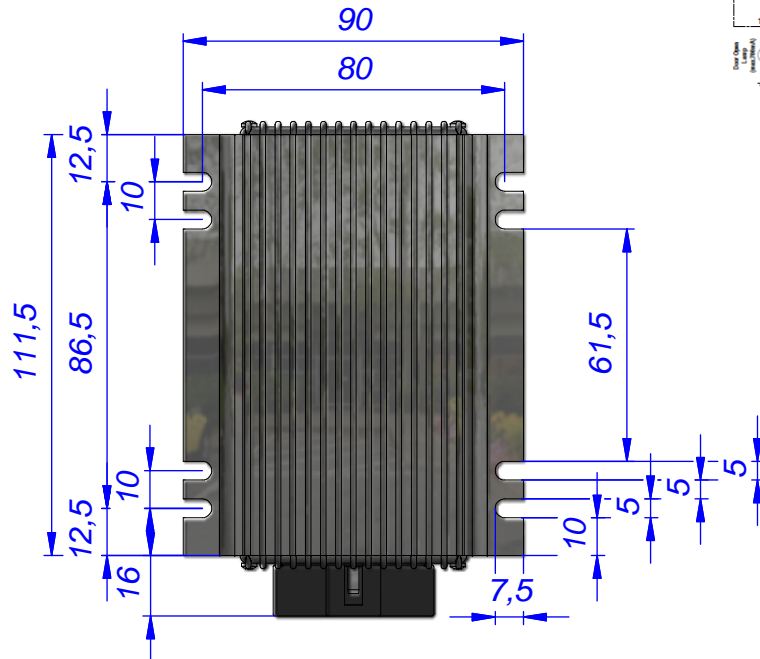
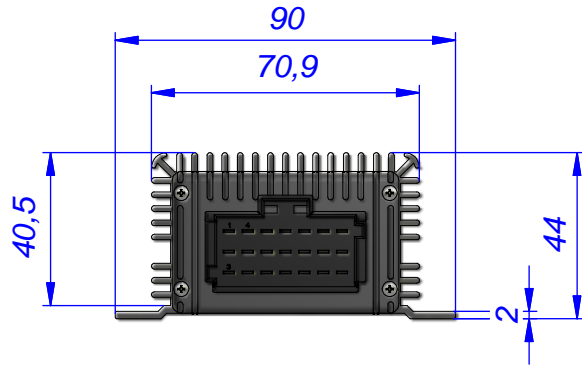

WORKING PRINCIPLE

- * DOUBLE DOOR TO DOOR CONTROL IS ON-OFF BUTTON.
- * SPEED SIGNAL INPUT 10Hz THEM THAT THE VEHICLE MOTION is detected.
- * WHEN THE DOOR OPENED IN CAR NAVIGATION.
- * DOOR OPEN WHILE THE DOOR OR gates close automatically when the vehicle moves.
- * GIVE BACK DOOR OPENING CLOSURE DURING THE BLOCK SIGNAL encounters.
- * OPENED DOOR LIGHT becomes active.
- Sherbet ENTRY DOOR EMERGENCY LEAVE THEM *

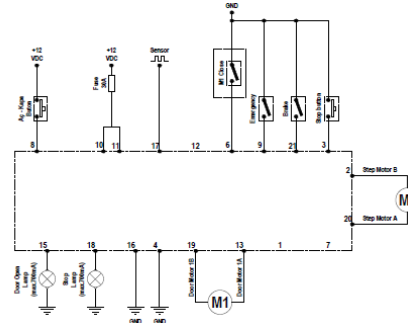

ANLAŞ : 005

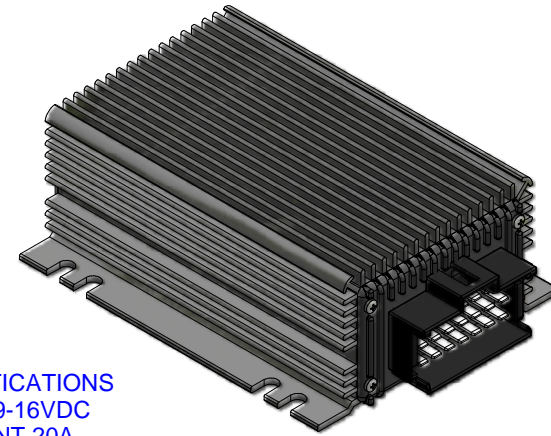

- 1 -) USED
- 2 -) PRINT ENGINE _B
- 3 -) STOP BUTTON
- 4 -) GND
- 5 -) USED
- 6 -) M1 OFF
- 7 -) USED
- 8 -) ON OFF BUTTON
- 9 -) EMERGENCY
- 10 -) V +
- 11 -) V +
- 12 -) USED
- 13 -) DOOR MOTOR 1A
- 14 -) KULLANILMIYOR
- 15 -) DOOR OPEN LIGHT
- 16 -) GND
- 17 -) SPEED
- 18 -) TAIL LAMP
- 19 -) DOOR MOTOR_1B
- 20 -) STEP MOTOR A
- 21 -) PARKING BRAKE

TECHNICAL SPECIFICATIONS
Operating voltage 9-16VDC
MOTOR CURRENT 20A
Quiescent current <30mA 12VDC
Operating temperature -40 °C / +85 °C

AD SOYAD NAME SURNAME	TARİH DATE	İMZA SIGNATURE	HAMMADDE MATERIAL	XXX
ÇİZEN PAINTER	Fatih YAVUZ	04.06.2012	DIN TOLERANSI DIN TOLERANCE	XXX
KONTROL TO CHECK	Kenan EFENDİOĞLU	04.06.2012	REVİZYON REVISION	0
ONAY TO APPROVE	Feyzi YENİZAĞRA	04.06.2012	ÖLÇEK SCALE	2/1

ANLAŞ KALIP
OTOBÜS MINİBÜS KAPI SİSTEMLERİ
BUS & MIDIBUS DOOR SYSTEMS

DEĞ.NO	TARİH	YAPAN	AÇIKLAMA
			DEĞİŞİKLİK

PARÇA ADI MATERIAL NAME	DÖNER SİSTEM TEK KANAT KAPI MEKANİZMA KARTI 12v (ANLAŞ 005)	A4

PARÇA NO MATERIAL NO	10 024 0111

TEKNİK RESİM ÜZERİNDEN ÖLÇÜ ALMAYINIZ
WE MUST TAKE THE TECHNICAL DRAWING MEASURE

BU RESİMİN İZİNSİZ ÜÇÜNCÜ ŞAHSILARA VERİLMESİ YASAKTIR AKSİ TAKTİRDE YASAL İŞLEM BAŞLATILACAKTIR.
THIS DRAWING MUSN'T ALLOW TO GIVE PROHIBIT FOR OHTER PERSON OTHERWISE WE WILL START LEGAL OPERATION