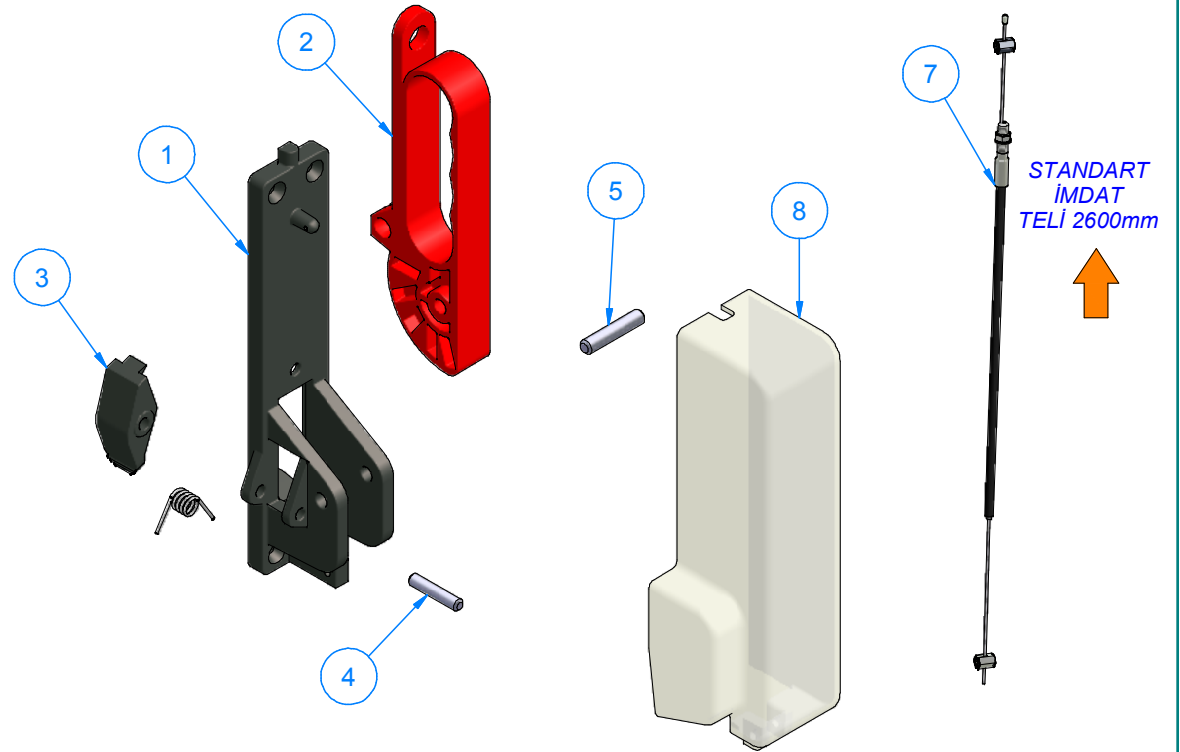
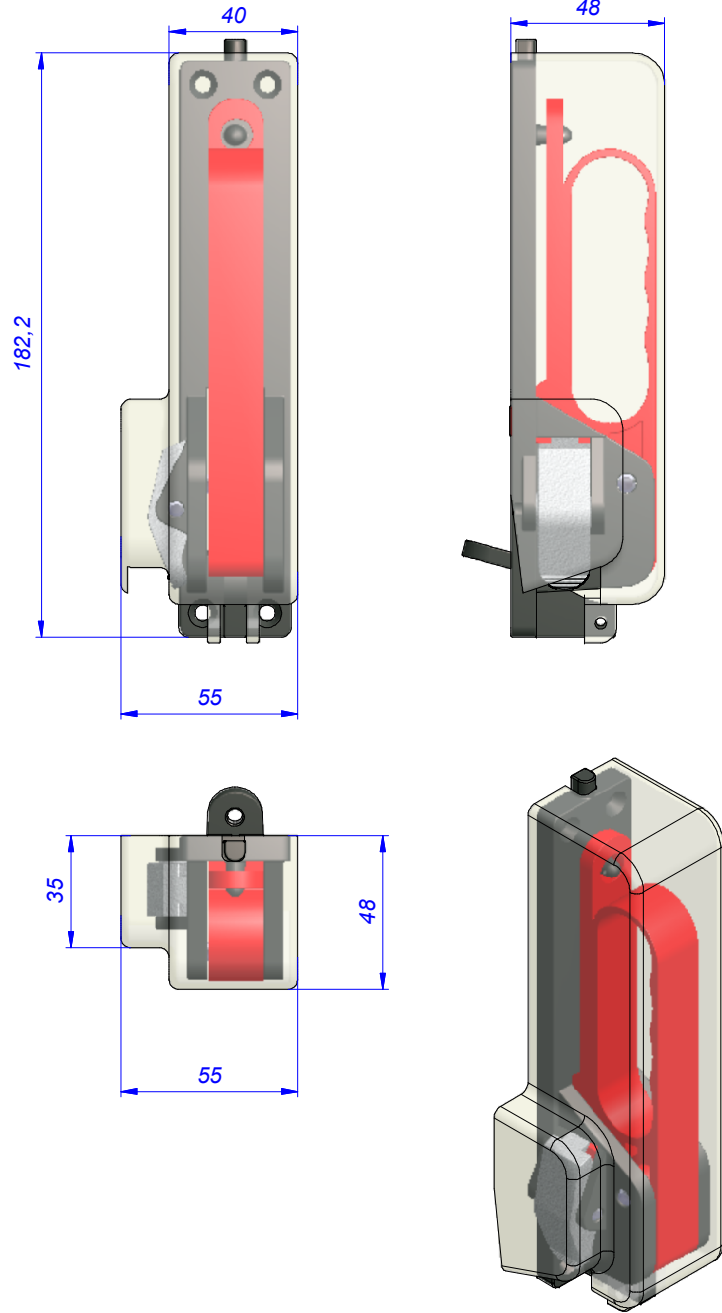

TÜM ÖLÇÜLER mm CİNSİNDENDİR.

STANDART  
İMDAT  
TELİ 2600mm

S.NO	PARÇA ADI	MALZEME	PARÇA NUMARASI	ADET
8	İÇ İMDAT MANDAL KAPAĞI	PLEXI GLASS	10 011 0306	1
7	2600mm STANDART İMDAT TEL Ø1.5 mm	XXX	10 009 0097	1
6	0.5.1 D2E İMDAT MANDALI YAYI	AISI 302	10 022 0100	1
5	0.5.1 İMDAT MANDAL DÜĞME PİMİ	6CE6 H6	10 021 3001	1
4	0.5.1 D2E İMDAT KOLU PİMİ	6CE6 H6	10 021 3000	1
3	0.5.1 D2E İMDAT MANDAL DÜĞMESİ SİYAH	10 007 0051	10 007 2310	1
2	0.5.1D2E İMDAT KOLU	N66C33	10 011 0145	1
1	0.5.1 D2E İMDAT MANDAL GÖVDESİ SİYAH	10 007 0050	10 007 2300	1

## PARÇA LİSTESİ

AD SOYAD NAME SURNAME	TARİH DATE	İMZA SIGNATURE	HAMMADDE MATERIAL	XXX
ÇİZEN PAINTER	Fatih YAVUZ	07.05.2013	DIN TOLERANSI DIN TOLERANCE	xxx
KONTROL TO CHECK	Arzu YANIK	07.05.2013	REVİZYON REVISION	A
ONAY TO APPROVE	Fatih YAVUZ	07.05.2013	ÖLÇEK SCALE	1/2
PARÇA ADI MATERIAL NAME	ACIL ÇIKIŞ İÇ İMDAT MANDALI KOMPLESİ VERSİYON 1.1			A3
PARÇA NO MATERIAL NO	70 150 5005			

TEKNİK RESİM ÜZERİNDEN ÖLÇÜ ALMAYINIZ  
BU RESİMİN İZİNSİZ ÜÇÜNCÜ ŞAHİSLARA VERİLMESİ YASAKTIR AKSİ TAKTİRDE YASAL İŞLEM BAŞLATILACAKTIR.  
WE MUST TAKE THE TECHNICAL DRAWING MEASURE  
THIS DRAWING MUSNT ALLOW TO GIVE PROHIBIT FOR OHTER PERSON OTHERWISE WE WILL START LEGAL OPERATION

ADRES : \192.168.2.200\TEKNİK BÜRO\2019\ÇİZİMLER\10\009\0097\10\_009\_0097.dwg